

“I” WELDED GUIDE RAILS

The “I” welded guide rails are obtained from the welding of laminated plates.

They are used in the same application fields as the “U” welded guide rails.

Jumbo series combination bearings are used inside these guides.

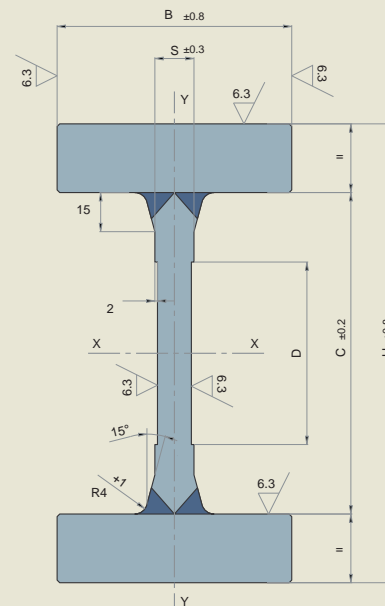

SPECIAL ORDER ITEM

Part Number	Nominal Capacity KN	Centre of Gravity mm	Dimensions					Moments of Inertia		Modulus of Resistance		WEIGHT Kg/m
			C	H	B	S	D	Jx Cm ⁴	Jy Cm ⁴	Wx Cm ³	Wy Cm ³	
FI 123	60	800	123,3	176	90	15	*	2960	325	336	72	52,8
FI 149	80	800	149,3	205	110	16	*	5320	615	519	112	68,7
FM 165	100	600	165,4	230	95	16	80	6825	475	593	100	71
FM 190	160	600	190,4	255	130	20	80	11983	1203	940	185	100
FM 220	180	1.200	220,4	295	150	20	125	21035	2123	1426	283	128
FM 250	280	1.200	250,4	345	160	25	125	37883	3279	2196	410	175
FM 280	360	1.200	280,4	375	190	30	125	55210	5498	2945	578	215
FM 280 R	420	1.200	280,4	395	190	30	125	69230	6642	3505	700	245

Material: UNI Fe 510 C – DIN St 52.3

The profiles are custom made for the customer's requirements. Maximum length is 10 m.